



FUKUCOM COMPANY LTD.

福 靈 有 限 公 司

FLAT P, 3/F., EVEREST INDUSTRIAL CENTRE, 396 KWUN TONG ROAD,
KWUN TONG, KOWLOON, HONG KONG.

TEL: 852-2790 0314 FAX: 852-2790 0206

KEC

**SEMICONDUCTOR
TECHNICAL DATA**

KTC9015S

EPITAXIAL PLANAR PNP TRANSISTOR

GENERAL PURPOSE APPLICATION.
SWITCHING APPLICATION.

FEATURES

- Excellent h_{FE} Linearity
: $h_{FE}(I_C=-0.1mA)/h_{FE}(I_C=-2mA)=0.95(\text{Typ.})$.
- Low Noise :NF=1dB(Typ.) at $f=1\text{kHz}$.
- Complementary to KTC9014S.

MAXIMUM RATING (Ta=25 °C)

CHARACTERISTIC	SYMBOL	RATING	UNIT
Collector-Base Voltage	V_{CBO}	-50	V
Collector-Emitter Voltage	V_{CEO}	-50	V
Emitter-Base Voltage	V_{EBO}	-5	V
Collector Current	I_C	-150	mA
Emitter Current	I_E	150	mA
Collector Power Dissipation	P_C^*	350	mW
Junction Temperature	T_j	150	°C
Storage Temperature Range	T_{stg}	-55 ~ 150	°C

* P_C : Package Mounted On 99.5% Alumina (10 × 8 × 0.6mm)

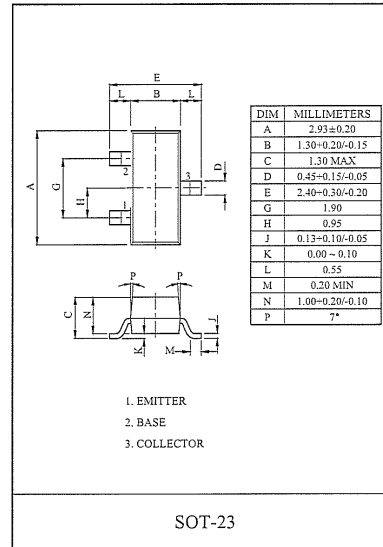

Marking

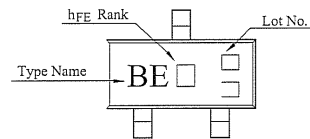

ELECTRICAL CHARACTERISTICS (Ta=25 °C)

CHARACTERISTIC	SYMBOL	TEST CONDITION	MIN.	TYP.	MAX.	UNIT
Collector Cut-off Current	I_{CBO}	$V_{CB}=-50V, I_E=0$	-	-	-50	nA
Emitter Cut-off Current	I_{EBO}	$V_{EB}=-5V, I_C=0$	-	-	-100	nA
DC Current Gain	h_{FE} (Note)	$V_{CE}=-5V, I_C=-1mA$	100	-	600	
Collector-Emitter Saturation Voltage	$V_{CE(sat)}$	$I_C=-100mA, I_E=-10mA$	-	-0.1	-0.3	V
Transition Frequency	f_T	$V_{CE}=-10V, I_C=-1mA, f=100\text{MHz}$	60	-	-	MHz
Collector Output Capacitance	C_{ob}	$V_{CB}=-10V, I_E=0, f=1\text{MHz}$	-	4.0	7.0	pF
Noise Figure	NF	$V_{CE}=-6V, I_C=-0.1mA, R_g=10k\Omega, f=1\text{kHz}$	-	1.0	10	dB

Note : h_{FE} Classification B:100 ~ 300, C:200 ~ 600



FUKUCOM COMPANY LTD.

福 靈 有 限 公 司

FLAT P, 3/F., EVEREST INDUSTRIAL CENTRE, 396 KWUN TONG ROAD,
KWUN TONG, KOWLOON, HONG KONG.

TEL: 852-2790 0314 FAX: 852-2790 0206

KTC9015S

