



FUKUCOM COMPANY LTD.

福 靈 有 限 公 司

FLAT P, 3/F., EVEREST INDUSTRIAL CENTRE, 396 KWUN TONG ROAD,
KWUN TONG, KOWLOON, HONG KONG.

TEL: 852-2790 0314 FAX: 852-2790 0206

FAIRCHILD
SEMICONDUCTOR®

www.fairchildsemi.com

KA78LXXA/KA78L05AA

3-Terminal 0.1A Positive Voltage Regulator

Features

- Maximum Output Current of 100mA
- Output Voltage of 5V, 6V, 8V, 9V, 10V, 12V, 15V, 18V and 24V
- Thermal Overload Protection
- Short Circuit Current Limiting
- Output Voltage Offered in $\pm 5\%$ Tolerance

Description

The KA78LXXA/KA78L05AA series of fixed voltage monolithic integrated circuit voltage regulators are suitable for application that required supply current up to 100mA.

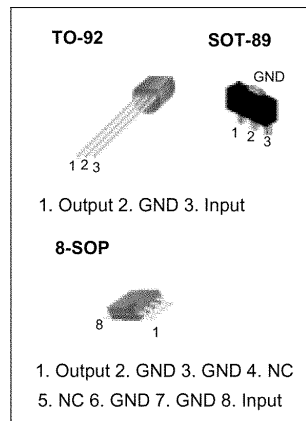

Internal Block Diagram

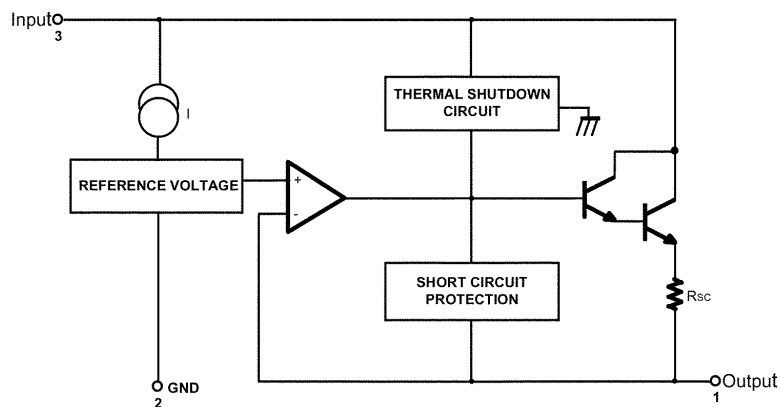

Rev. 1.0.4



FUKUCOM COMPANY LTD.

福 靈 有 限 公 司

FLAT P, 3/F., EVEREST INDUSTRIAL CENTRE, 396 KWUN TONG ROAD,
KWUN TONG, KOWLOON, HONG KONG.

TEL: 852-2790 0314 FAX: 852-2790 0206

KA78LXXA/KA78L05AA

Absolute Maximum Ratings

Parameter	Symbol	Value	Unit
Input Voltage (for $V_O = 5V, 8V$) (for $V_O = 12V$ to $18V$) (for $V_O = 24V$)	V_I	30 35 40	V V V
Operating Junction Temperature Range	T_J	0 ~ +150	°C
Storage Temperature Range	T_{STG}	-65 ~ +150	°C

Electrical Characteristics(KA78L05A)

($V_I = 10V, I_O = 40mA, 0^\circ C \leq T_J \leq 125^\circ C, C_I = 0.33\mu F, C_O = 0.1\mu F$, unless otherwise specified. (Note1))

Parameter	Symbol	Conditions	Min.	Typ.	Max.	Unit	
Output Voltage	V_O	$T_J = 25^\circ C$	4.8	5.0	5.2	V	
Line Regulation (Note1)	ΔV_O	$T_J = 25^\circ C$	$7V \leq V_I \leq 20V$	-	8	150	mV
			$8V \leq V_I \leq 20V$	-	6	100	mV
Load Regulation (Note1)	ΔV_O	$T_J = 25^\circ C$	$1mA \leq I_O \leq 100mA$	-	11	60	mV
			$1mA \leq I_O \leq 40mA$	-	5.0	30	mV
Output Voltage	V_O	$7V \leq V_I \leq 20V$	$1mA \leq I_O \leq 40mA$	-	-	5.25	V
		$7V \leq V_I \leq V_{MAX}$ (Note 2)	$1mA \leq I_O \leq 70mA$	4.75	-	5.25	V
Quiescent Current	I_Q	$T_J = 25^\circ C$	-	2.0	5.5	mA	
Quiescent Current Change	with line	ΔI_Q	$8V \leq V_I \leq 20V$	-	-	1.5	mA
	with load	ΔI_Q	$1mA \leq I_O \leq 40mA$	-	-	0.1	mA
Output Noise Voltage	V_N	$T_A = 25^\circ C, 10Hz \leq f \leq 100kHz$	-	40	-	$\mu V/V_O$	
Temperature Coefficient of V_O	$\Delta V_O/\Delta T$	$I_O = 5mA$	-	-0.65	-	$mV/^\circ C$	
Ripple Rejection	RR	$f = 120Hz, 8V \leq V_I \leq 18V, T_J = 25^\circ C$	41	80	-	dB	
Dropout Voltage	V_D	$T_J = 25^\circ C$	-	1.7	-	V	

Note:

- The maximum steady state usable output current and input voltage are very dependent on the heat sinking and/or lead length of the package. The data above represent pulse test conditions with junction temperature as indicated at the initiation of tests.
- Power dissipation $P_D \leq 0.75W$.



FUKUCOM COMPANY LTD.

福 靈 有 限 公 司

FLAT P, 3/F., EVEREST INDUSTRIAL CENTRE, 396 KWUN TONG ROAD,
KWUN TONG, KOWLOON, HONG KONG.

TEL: 852-2790 0314 FAX: 852-2790 0206

KA78LXXA/KA78L05AA

Electrical Characteristics(KA78L06A) (Continued)

($V_I = 12V$, $I_O = 40mA$, $0^\circ C \leq T_J \leq 125^\circ C$, $C_I = 0.33\mu F$, $C_O = 0.1\mu F$, unless otherwise specified. (Note 1))

Parameter	Symbol	Conditions	Min.	Typ.	Max.	Unit	
Output Voltage	V_O	$T_J = 25^\circ C$	5.75	6.0	6.25	V	
Line Regulation (Note1)	ΔV_O	$T_J = 25^\circ C$	$8.5V \leq V_I \leq 20V$	-	64	175	mV
			$9V \leq V_I \leq 20V$	-	54	125	mV
Load Regulation (Note1)	ΔV_O	$T_J = 25^\circ C$	$1mA \leq I_O \leq 100mA$	-	12.8	80	mV
			$1mA \leq I_O \leq 70mA$	-	5.8	40	mV
Output Voltage	V_O	$8.5 \leq V_I \leq 20V$, $1mA \leq I_O \leq 40mA$	5.7	-	6.3	V	
		$8.5 \leq V_I \leq V_{MAX}(\text{Note})$, $1mA \leq I_O \leq 70mA$	5.7	-	6.3	V	
Quiescent Current	I_Q	$T_J = 25^\circ C$	-	-	5.5	mA	
		$T_J = 125^\circ C$	-	3.9	6.0	mA	
Quiescent Current Change	with line	ΔI_Q	$9 \leq V_I \leq 20V$	-	-	1.5	mA
	with load	ΔI_Q	$1mA \leq I_O \leq 40mA$	-	-	0.1	mA
Output Noise Voltage	V_N	$T_A = 25^\circ C$, $10Hz \leq f \leq 100kHz$	-	40	-	$\mu V/V_O$	
Temperature Coefficient of V_O	$\Delta V_O/\Delta T$	$I_O = 5mA$	-	0.75	-	$mV/^\circ C$	
Ripple Rejection	RR	$f = 120Hz$, $10V \leq V_I \leq 20V$, $T_J = 25^\circ C$	40	46	-	dB	
Dropout Voltage	V_D	$T_J = 25^\circ C$	-	1.7	-	V	

Note:

1. The maximum steady state usable output current and input voltage are very dependent on the heat sinking and/or lead length of the package. The data above represent pulse test conditions with junction temperature as indicated at the initiation of tests.
2. Power dissipation $P_D \leq 0.75W$.



FUKUCOM COMPANY LTD.

福 靈 有 限 公 司

FLAT P, 3/F., EVEREST INDUSTRIAL CENTRE, 396 KWUN TONG ROAD,
KWUN TONG, KOWLOON, HONG KONG.

TEL: 852-2790 0314 FAX: 852-2790 0206

KA78LXXA/KA78L05AA

Electrical Characteristics(KA78L08A) (Continued)

($V_I = 14V$, $I_O = 40mA$, $0^\circ C \leq T_J \leq 125^\circ C$, $C_I = 0.33\mu F$, $C_O = 0.1\mu F$, unless otherwise specified. (Note 1))

Parameter	Symbol	Conditions	Min.	Typ.	Max.	Unit	
Output Voltage	V_O	$T_J = 25^\circ C$	7.7	8.0	8.3	V	
Line Regulation (Note1)	ΔV_O	$T_J = 25^\circ C$	$10.5V \leq V_I \leq 23V$	-	10	175	mV
			$11V \leq V_I \leq 23V$	-	8	125	mV
Load Regulation (Note1)	ΔV_O	$T_J = 25^\circ C$	$1mA \leq I_O \leq 100mA$	-	15	80	mV
			$1mA \leq I_O \leq 40mA$	-	8.0	40	mV
Output Voltage	V_O	$10.5V \leq V_I \leq 23V$	$1mA \leq I_O \leq 40mA$	7.6	-	8.4	V
		$10.5V \leq V_I \leq V_{MAX}$ (Note 2)	$1mA \leq I_O \leq 70mA$	7.6	-	8.4	V
Quiescent Current	I_Q	$T_J = 25^\circ C$	-	2.0	5.5	mA	
Quiescent Current Change	with line	ΔI_Q	$11V \leq V_I \leq 23V$	-	-	1.5	mA
	with load	ΔI_Q	$1mA \leq I_O \leq 40mA$	-	-	0.1	mA
Output Noise Voltage	V_N	$T_A = 25^\circ C$, $10Hz \leq f \leq 100kHz$	-	60	-	$\mu V/V_O$	
Temperature Coefficient of V_O	$\Delta V_O/\Delta T$	$I_O = 5mA$	-	-0.8	-	$mV/^\circ C$	
Ripple Rejection	RR	$f = 120Hz$, $11V \leq V_I \leq 21V$, $T_J = 25^\circ C$	39	70	-	dB	
Dropout Voltage	V_D	$T_J = 25^\circ C$	-	1.7	-	V	

Note:

1. The maximum steady state usable output current and input voltage are very dependent on the heat sinking and/or lead length of the package. The data above represent pulse test conditions with junction temperature as indicated at the initiation of tests.
2. Power dissipation $P_D \leq 0.75W$.

**FUKUCOM COMPANY LTD.****福 靈 有 限 公 司**FLAT P, 3/F., EVEREST INDUSTRIAL CENTRE, 396 KWUN TONG ROAD,
KWUN TONG, KOWLOON, HONG KONG.

TEL: 852-2790 0314 FAX: 852-2790 0206

KA78LXXA/KA78L05AA

Electrical Characteristics(KA78L09A) (Continued)(V_I = 15V, I_O = 40mA, 0°C ≤ T_J ≤ 125°C, C_I = 0.33μF, C_O = 0.1μF, unless otherwise specified. (Note 1))

Parameter	Symbol	Conditions	Min.	Typ.	Max.	Unit	
Output Voltage	V _O	T _J = 25°C	8.64	9.0	9.36	V	
Line Regulation (Note1)	ΔV _O	T _J = 25°C	11.5V ≤ V _I ≤ 24V	-	90	200	mV
			13V ≤ V _I ≤ 24V	-	100	150	mV
Load Regulation (Note1)	ΔV _O	T _J = 25°C	1mA ≤ I _O ≤ 100mA	-	20	90	mV
			1mA ≤ I _O ≤ 40mA	-	10	45	mV
Output Voltage	V _O	11.5V ≤ V _I ≤ 24V	1mA ≤ I _O ≤ 40mA	8.55	-	9.45	V
		11.5V ≤ V _I ≤ V _{MAX} (Note 2)	1mA ≤ I _O ≤ 70mA	8.55	-	9.45	V
Quiescent Current	I _Q	T _J = 25°C	-	2.1	6.0	mA	
Quiescent Current Change	with line	ΔI _Q	13V ≤ V _I ≤ 24V	-	-	1.5	mA
	with load	ΔI _Q	1mA ≤ I _O ≤ 40mA	-	-	0.1	mA
Output Noise Voltage	V _N	T _A = 25°C, 10Hz ≤ f ≤ 100kHz	-	70	-	μV/V _O	
Temperature Coefficient of V _O	ΔV _O /ΔT	I _O = 5mA	-	-0.9	-	mV/°C	
Ripple Rejection	RR	f = 120Hz, 12V ≤ V _I ≤ 22V, T _J = 25°C	38	44	-	dB	
Dropout Voltage	V _D	T _J = 25°C	-	1.7	-	V	

Note:

1. The maximum steady state usable output current and input voltage are very dependent on the heat sinking and/or lead length of the package. The data above represent pulse test conditions with junction temperature as indicated at the initiation of tests.
2. Power dissipation P_D ≤ 0.75W.



FUKUCOM COMPANY LTD.

福 靈 有 限 公 司

FLAT P, 3/F., EVEREST INDUSTRIAL CENTRE, 396 KWUN TONG ROAD,
KWUN TONG, KOWLOON, HONG KONG.

TEL: 852-2790 0314 FAX: 852-2790 0206

KA78LXXA/KA78L05AA

Electrical Characteristics(KA78L10A) (Continued)

($V_I = 16V$, $I_O = 40mA$, $0^\circ C \leq T_J \leq 125^\circ C$, $C_I = 0.33 \mu F$, $C_O = 0.1 \mu F$, unless otherwise specified. (Note 1))

Parameter	Symbol	Conditions	Min.	Typ.	Max.	Unit	
Output Voltage	V_O	$T_J = 25^\circ C$	9.6	10.0	10.4	V	
Line Regulation (Note1)	ΔV_O	$T_J = 25^\circ C$	$12.5 \leq V_I \leq 25V$	-	100	220	mV
			$14V \leq V_I \leq 25V$	-	100	170	mV
Load Regulation (Note1)	ΔV_O	$T_J = 25^\circ C$	$1mA \leq I_O \leq 100mA$	-	20	94	mV
			$1mA \leq I_O \leq 70mA$	-	10	47	mV
Output Voltage	V_O	$12.5V \leq V_I \leq 25V$, $1mA \leq I_O \leq 40mA$	9.5	-	10.5	V	
		$12.5V \leq V_I \leq V_{MAX}$ (Note2) $1mA \leq I_O \leq 70mA$	9.5	-	10.5		
Quiescent Current	I_Q	$T_J = 25^\circ C$	-	-	6.0	mA	
		$T_J = 125^\circ C$	-	4.2	6.5		
Quiescent Current Change	with line	ΔI_Q	$12.5 \leq V_I \leq 25V$	-	-	1.5	mA
	with load	ΔI_Q	$1mA \leq I_O \leq 40mA$	-	-	0.1	mA
Output Noise Voltage	V_N	$T_A = 25^\circ C$, $10Hz \leq f \leq 100kHz$	-	74	-	$\mu V/V_O$	
Temperature Coefficient of V_O	$\Delta V_O/\Delta T$	$I_O = 5mA$	-	0.95	-	mV/ $^\circ C$	
Ripple Rejection	RR	$f = 120Hz$, $15V \leq V_I \leq 25V$, $T_J = 25^\circ C$	38	43	-	dB	
Dropout Voltage	V_D	$T_J = 25^\circ C$	-	1.7	-	V	

Notes:

1. The maximum steady state usable output current and input voltage are very dependent on the heat sinking and/or lead length of the package. The data above represent pulse test conditions with junction temperature as indicated at the initiation of tests.
2. Power dissipation $P_D \leq 0.75W$.



FUKUCOM COMPANY LTD.

福 靈 有 限 公 司

FLAT P, 3/F., EVEREST INDUSTRIAL CENTRE, 396 KWUN TONG ROAD,
KWUN TONG, KOWLOON, HONG KONG.

TEL: 852-2790 0314 FAX: 852-2790 0206

KA78LXXA/KA78L05AA

Electrical Characteristics(KA78L12A) (Continued)

($V_I = 19V$, $I_O = 40mA$, $0^\circ C \leq T_J \leq 125^\circ C$, $C_I = 0.33 \mu F$, $C_O = 0.1 \mu F$, unless otherwise specified. (Note 1))

Parameter	Symbol	Conditions	Min.	Typ.	Max.	Unit	
Output Voltage	V_O	$T_J = 25^\circ C$	11.5	12	12.5	V	
Line Regulation (Note1)	ΔV_O	$T_J = 25^\circ C$	$14.5V \leq V_I \leq 27V$	-	20	250	mV
			$16V \leq V_I \leq 27V$	-	15	200	mV
Load Regulation (Note1)	ΔV_O	$T_J = 25^\circ C$	$1mA \leq I_O \leq 100mA$	-	20	100	mV
			$1mA \leq I_O \leq 40mA$	-	10	50	mV
Output Voltage	V_O	$14.5V \leq V_I \leq 27V$	$1mA \leq I_O \leq 40mA$	11.4	-	12.6	V
		$14.5V \leq V_I \leq V_{MAX}$ (Note 2)	$1mA \leq I_O \leq 70mA$	11.4	-	12.6	V
Quiescent Current	I_Q	$T_J = 25^\circ C$	-	2.1	6.0	mA	
Quiescent Current Change	with line	ΔI_Q	$16V \leq V_I \leq 27V$	-	-	1.5	mA
	with load	ΔI_Q	$1mA \leq I_O \leq 40mA$	-	-	0.1	mA
Output Noise Voltage	V_N	$T_A = 25^\circ C$, $10Hz \leq f \leq 100kHz$	-	80	-	$\mu V/V_O$	
Temperature Coefficient of V_O	$\Delta V_O/\Delta T$	$I_O = 5mA$	-	-1.0	-	mV/ $^\circ C$	
Ripple Rejection	RR	$f = 120Hz$, $15V \leq V_I \leq 25V$, $T_J = 25^\circ C$	37	65	-	dB	
Dropout Voltage	V_D	$T_J = 25^\circ C$	-	1.7	-	V	

Note:

- The maximum steady state usable output current and input voltage are very dependent on the heat sinking and/or lead length of the package. The data above represent pulse test conditions with junction temperature as indicated at the initiation of tests.
- Power dissipation $P_D \leq 0.75W$.



FUKUCOM COMPANY LTD.

福 靈 有 限 公 司

FLAT P, 3/F., EVEREST INDUSTRIAL CENTRE, 396 KWUN TONG ROAD,
KWUN TONG, KOWLOON, HONG KONG.

TEL: 852-2790 0314 FAX: 852-2790 0206

KA78LXXA/KA78L05AA

Electrical Characteristics(KA78L15A) (Continued)

($V_I = 23V$, $I_O = 40mA$, $0^\circ C \leq T_J \leq 125^\circ C$, $C_I = 0.33 \mu F$, $C_O = 0.1 \mu F$, unless otherwise specified. (Note 1))

Parameter	Symbol	Conditions	Min.	Typ.	Max.	Unit	
Output Voltage	V_O	$T_J = 25^\circ C$	14.4	15	15.6	V	
Line Regulation (Note1)	ΔV_O	$T_J = 25^\circ C$	$17.5V \leq V_I \leq 30V$	-	25	300	mV
			$20V \leq V_I \leq 30V$	-	20	250	mV
Load Regulation (Note1)	ΔV_O	$T_J = 25^\circ C$	$1mA \leq I_O \leq 100mA$	-	25	150	mV
			$1mA \leq I_O \leq 40mA$	-	12	75	mV
Output Voltage	V_O	$17.5V \leq V_I \leq 30V$	$1mA \leq I_O \leq 40mA$	14.25	-	15.75	V
		$17.5V \leq V_I \leq V_{MAX}$ (Note 2)	$1mA \leq I_O \leq 70mA$	14.25	-	15.75	V
Quiescent Current	I_Q	$T_J = 25^\circ C$	-	2.1	6.0	mA	
Quiescent Current Change	with line	ΔI_Q	$20V \leq V_I \leq 30V$	-	-	1.5	mA
	with load	ΔI_Q	$1mA \leq I_O \leq 40mA$	-	-	0.1	mA
Output Noise Voltage	V_N	$T_A = 25^\circ C$, $10Hz \leq f \leq 100kHz$	-	90	-	$\mu V/V_O$	
Temperature Coefficient of V_O	$\Delta V_O/\Delta T$	$I_O = 5mA$	-	-1.3	-	$mV/^\circ C$	
Ripple Rejection	RR	$f = 120Hz$, $18.5V \leq V_I \leq 28.5V$, $T_J = 25^\circ C$	34	60	-	dB	
Dropout Voltage	V_D	$T_J = 25^\circ C$	-	1.7	-	V	

Note:

1. The maximum steady state usable output current and input voltage are very dependent on the heat sinking and/or lead length of the package. The data above represent pulse test conditions with junction temperature as indicated at the initiation of tests.
2. Power dissipation $P_D \leq 0.75W$.



FUKUCOM COMPANY LTD.

福 靈 有 限 公 司

FLAT P, 3/F., EVEREST INDUSTRIAL CENTRE, 396 KWUN TONG ROAD,
KWUN TONG, KOWLOON, HONG KONG.

TEL: 852-2790 0314 FAX: 852-2790 0206

KA78LXXA/KA78L05AA

Electrical Characteristics(KA78L18A) (Continued)

($V_I = 27V$, $I_O = 40mA$, $0^\circ C \leq T_J \leq 125^\circ C$, $C_I = 0.33 \mu F$, $C_O = 0.1 \mu F$, unless otherwise specified. (Note 1))

Parameter	Symbol	Conditions	Min.	Typ.	Max.	Unit	
Output Voltage	V_O	$T_J = 25^\circ C$	17.3	18	18.7	V	
Line Regulation (Note1)	ΔV_O	$T_J = 25^\circ C$	$21V \leq V_I \leq 33V$	-	145	300	mV
			$22V \leq V_I \leq 33V$	-	135	250	mV
Load Regulation (Note1)	ΔV_O	$T_J = 25^\circ C$	$1mA \leq I_O \leq 100mA$	-	30	170	mV
			$1mA \leq I_O \leq 40mA$	-	15	85	mV
Output Voltage	V_O	$21V \leq V_I \leq 33V$	$1mA \leq I_O \leq 40mA$	17.1	-	18.9	V
		$21V \leq V_I \leq V_{MAX}$ (Note 2)	$1mA \leq I_O \leq 70mA$	17.1	-	18.9	V
Quiescent Current	I_Q	$T_J = 25^\circ C$	-	2.2	6.0	mA	
Quiescent Current Change	with line	ΔI_Q	$21V \leq V_I \leq 33V$	-	-	1.5	mA
	with load	ΔI_Q	$1mA \leq I_O \leq 40mA$	-	-	0.1	mA
Output Noise Voltage	V_N	$T_A = 25^\circ C$, $10Hz \leq f \leq 100kHz$	-	150	-	$\mu V/V_O$	
Temperature Coefficient of V_O	$\Delta V_O/\Delta T$	$I_O = 5mA$	-	-1.8	-	$mV/^\circ C$	
Ripple Rejection	RR	$f = 120Hz$, $23V \leq V_I \leq 33V$, $T_J = 25^\circ C$	34	48	-	dB	
Dropout Voltage	V_D	$T_J = 25^\circ C$	-	1.7	-	V	

Note:

1. The maximum steady state usable output current and input voltage are very dependent on the heat sinking and/or lead length of the package. The data above represent pulse test conditions with junction temperature as indicated at the initiation of tests.
2. Power dissipation $P_D \leq 0.75W$.



FUKUCOM COMPANY LTD.

福 靈 有 限 公 司

FLAT P, 3/F., EVEREST INDUSTRIAL CENTRE, 396 KWUN TONG ROAD,
KWUN TONG, KOWLOON, HONG KONG.

TEL: 852-2790 0314 FAX: 852-2790 0206

KA78LXXA/KA78L05AA

Electrical Characteristics(KA78L24A) (Continued)

($V_I = 33V$, $I_O = 40mA$, $0^\circ C \leq T_J \leq 125^\circ C$, $C_I = 0.33 \mu F$, $C_O = 0.1 \mu F$, unless otherwise specified. (Note 1))

Parameter	Symbol	Conditions	Min.	Typ.	Max.	Unit	
Output Voltage	V_O	$T_J = 25^\circ C$	23	24	25	V	
Line Regulation (Note1)	ΔV_O	$T_J = 25^\circ C$	$27V \leq V_I \leq 38V$	-	160	300	mV
			$28V \leq V_I \leq 38V$	-	150	250	mV
Load Regulation (Note1)	ΔV_O	$T_J = 25^\circ C$	$1mA \leq I_O \leq 100mA$	-	40	200	mV
			$1mA \leq I_O \leq 40mA$	-	20	100	mV
Output Voltage	V_O	$27V \leq V_I \leq 38V$	$1mA \leq I_O \leq 40mA$	22.8	-	25.2	V
		$27V \leq V_I \leq V_{MAX}$ (Note 2)	$1mA \leq I_O \leq 70mA$	22.8	-	25.2	V
Quiescent Current	I_Q	$T_J = 25^\circ C$	-	2.2	6.0	mA	
Quiescent Current Change	with line	ΔI_Q	$28V \leq V_I \leq 38V$	-	-	1.5	mA
	with load	ΔI_Q	$1mA \leq I_O \leq 40mA$	-	-	0.1	mA
Output Noise Voltage	V_N	$T_A = 25^\circ C$, $10Hz \leq f \leq 100kHz$	-	200	-	$\mu V/V_O$	
Temperature Coefficient of V_O	$\Delta V_O/\Delta T$	$I_O = 5mA$	-	-2.0	-	$mV/^\circ C$	
Ripple Rejection	RR	$f = 120Hz$, $28V \leq V_I \leq 38V$, $T_J = 25^\circ C$	34	45	-	dB	
Dropout Voltage	V_D	$T_J = 25^\circ C$	-	1.7	-	V	

Note:

1. The maximum steady state usable output current and input voltage are very dependent on the heat sinking and/or lead length of the package. The data above represent pulse test conditions with junction temperature as indicated at the initiation of tests.
2. Power dissipation $P_D \leq 0.75W$.

**FUKUCOM COMPANY LTD.****福 靈 有 限 公 司**FLAT P, 3/F., EVEREST INDUSTRIAL CENTRE, 396 KWUN TONG ROAD,
KWUN TONG, KOWLOON, HONG KONG.

TEL: 852-2790 0314 FAX: 852-2790 0206

KA78LXXA/KA78L05AA

Absolute Maximum Ratings

Parameter	Symbol	Value	Unit
Input Voltage (for $V_O = 5V, 8V$) (for $V_O = 12V$ to $18V$) (for $V_O = 24V$)	V_I	30 35 40	V V V
Operating Junction Temperature Range	T_J	0 ~ +150	°C
Storage Temperature Range	T_{STG}	-65 ~ +150	°C

Electrical Characteristics(KA78L05AA) (Continued) $(V_I = 10V, I_O = 40mA, 0^\circ C \leq T_J \leq 125^\circ C, C_I = 0.33 \mu F, C_O = 0.1 \mu F, \text{ unless otherwise specified. (Note 1)})$

Parameter	Symbol	Conditions	Min.	Typ.	Max.	Unit	
Output Voltage	V_O	$T_J = 25^\circ C$	4.9	5.0	5.1	V	
Line Regulation (Note1)	ΔV_O	$T_J = 25^\circ C$	$7V \leq V_I \leq 20V$	-	8	150	mV
			$8V \leq V_I \leq 20V$	-	6	100	mV
Load Regulation (Note1)	ΔV_O	$T_J = 25^\circ C$	$1mA \leq I_O \leq 100mA$	-	11	50	mV
			$1mA \leq I_O \leq 40mA$	-	5.0	25	mV
Output Voltage	V_O	$7V \leq V_I \leq 20V$	$1mA \leq I_O \leq 40mA$	-	-	5.15	V
		$7V \leq V_I \leq V_{MAX}$ (Note 2)	$1mA \leq I_O \leq 70mA$	4.85	-	5.15	V
Quiescent Current	I_Q	$T_J = 25^\circ C$	-	2.0	5.5	mA	
Quiescent Current Change	with line	ΔI_Q	$8V \leq V_I \leq 20V$	-	-	1.5	mA
	with load	ΔI_Q	$1mA \leq I_O \leq 40mA$	-	-	0.1	mA
Output Noise Voltage	V_N	$T_A = 25^\circ C, 10Hz \leq f \leq 100kHz$	-	40	-	$\mu V/V_O$	
Temperature Coefficient of V_O	$\Delta V_O/\Delta T$	$I_O = 5mA$	-	-0.65	-	$mV/^\circ C$	
Ripple Rejection	RR	$f = 120Hz, 8V \leq V_I \leq 18V, T_J = 25^\circ C$	41	80	-	dB	
Dropout Voltage	V_D	$T_J = 25^\circ C$	-	1.7	-	V	

Note:

1. The maximum steady state usable output current and input voltage are very dependent on the heat sinking and/or lead length of the package. The data above represent pulse test conditions with junction temperature as indicated at the initiation of tests.
2. Power dissipation $P_D \leq 0.75W$.



FUKUCOM COMPANY LTD.

福 靈 有 限 公 司

FLAT P, 3/F., EVEREST INDUSTRIAL CENTRE, 396 KWUN TONG ROAD,
KWUN TONG, KOWLOON, HONG KONG.

TEL: 852-2790 0314 FAX: 852-2790 0206

KA78LXXA/KA78L05AA

Typical Application

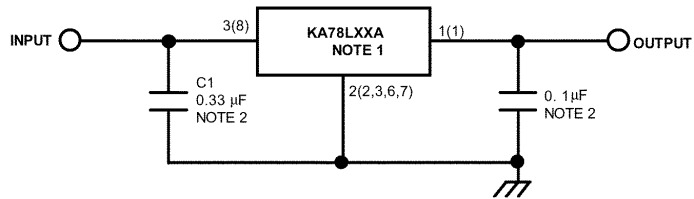

'()' : 8SOP Type

Notes:

1. To specify an output voltage, substitute voltage value for "XX".
2. Bypass Capacitors are recommend for optimum stability and transient response and should be located as close as possible to the regulator



FUKUCOM COMPANY LTD.

福 靈 有 限 公 司

FLAT P, 3/F., EVEREST INDUSTRIAL CENTRE, 396 KWUN TONG ROAD,
KWUN TONG, KOWLOON, HONG KONG.

TEL: 852-2790 0314 FAX: 852-2790 0206

KA78LXXA/KA78L05AA

Mechanical Dimensions

Package

Dimensions in millimeters

TO-92

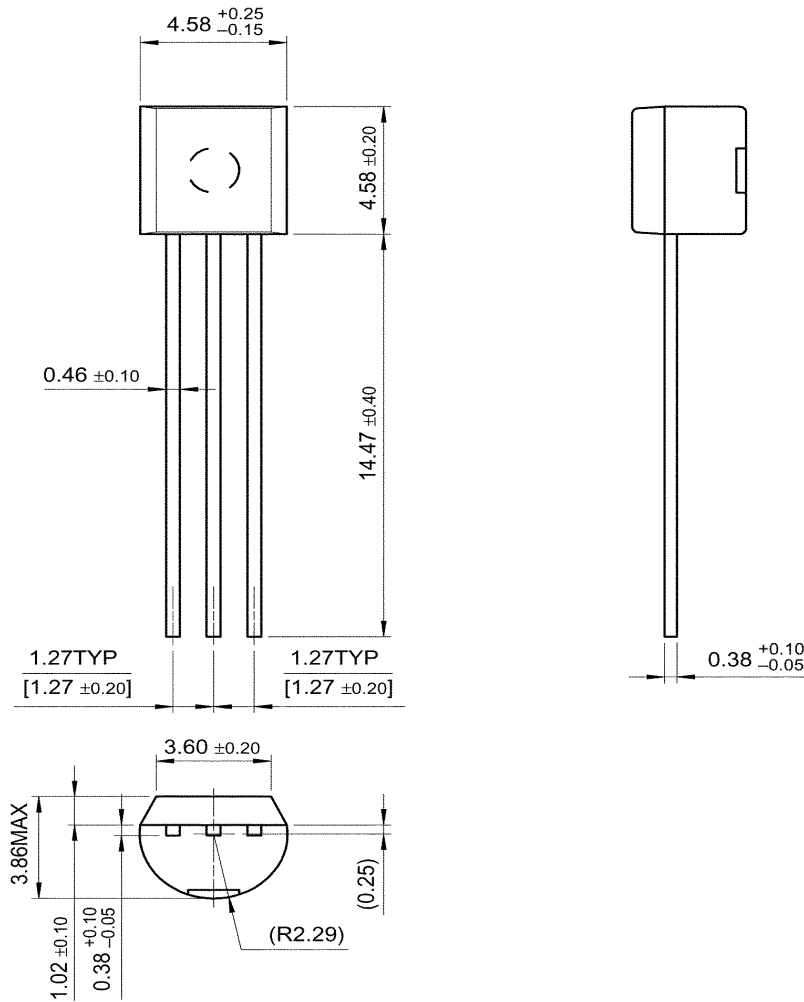



FUKUCOM COMPANY LTD.

福 靈 有 限 公 司

FLAT P, 3/F., EVEREST INDUSTRIAL CENTRE, 396 KWUN TONG ROAD,
KWUN TONG, KOWLOON, HONG KONG.

TEL: 852-2790 0314 FAX: 852-2790 0206

KA78LXXA/KA78L05AA

Mechanical Dimensions (Continued)

Package

Dimensions in millimeters

8-SOP

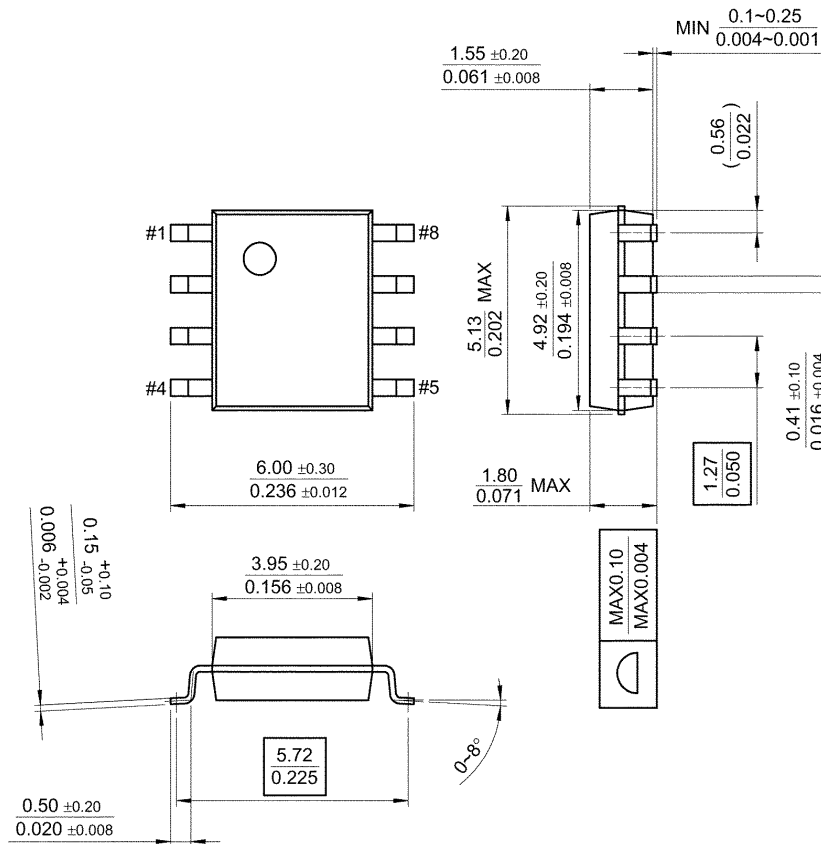



FUKUCOM COMPANY LTD.

福 靈 有 限 公 司

FLAT P, 3/F., EVEREST INDUSTRIAL CENTRE, 396 KWUN TONG ROAD,
KWUN TONG, KOWLOON, HONG KONG.

TEL: 852-2790 0314 FAX: 852-2790 0206

KA78LXXA/KA78L05AA

Mechanical Dimensions (Continued)

Package

Dimensions in millimeters

SOT-89

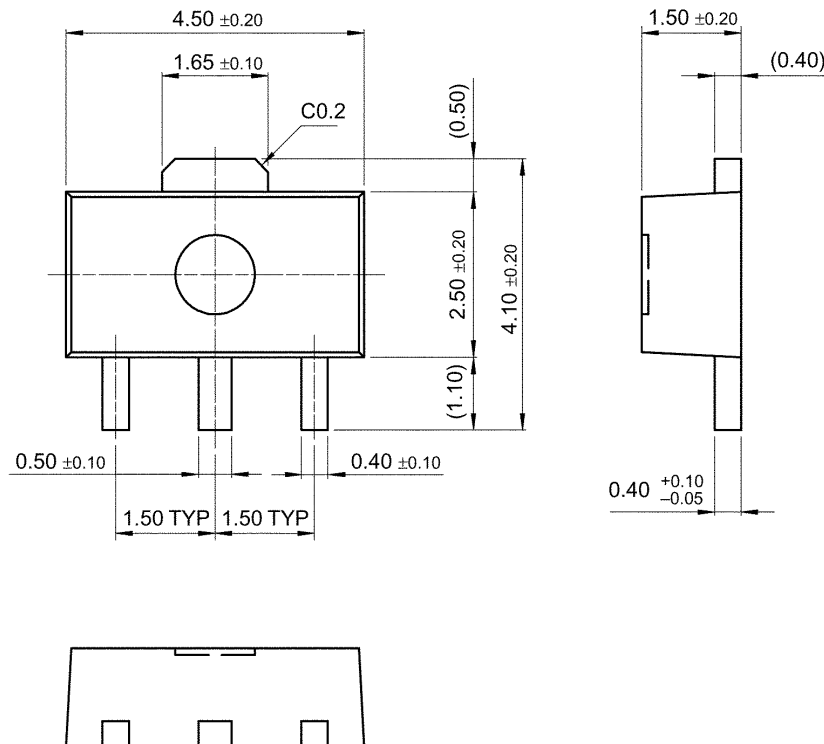



FUKUCOM COMPANY LTD.

福 靈 有 限 公 司

FLAT P, 3/F., EVEREST INDUSTRIAL CENTRE, 396 KWUN TONG ROAD,
KWUN TONG, KOWLOON, HONG KONG.

TEL: 852-2790 0314 FAX: 852-2790 0206

KA78LXXA/KA78L05AA

Ordering Information

Product Number	Package	Output Voltage Tolerance	Operating Temperature				
KA78L05AZ	TO-92	5%	0 ~ +125 °C				
KA78L06AZ							
KA78L08AZ							
KA78L09AZ							
KA78L10AZ							
KA78L12AZ							
KA78L15AZ							
KA78L18AZ							
KA78L24AZ							
KA78L05AD	8-SOP	5%	0 ~ +125 °C				
KA78L08AD							
KA78L12AD							
KA78L05AM	SOT-89			5%	0 ~ +125 °C		
KA78L08AM							
KA78L12AM							
KA78L05AAZ	TO-92					2%	

DISCLAIMER

FAIRCHILD SEMICONDUCTOR RESERVES THE RIGHT TO MAKE CHANGES WITHOUT FURTHER NOTICE TO ANY PRODUCTS HEREIN TO IMPROVE RELIABILITY, FUNCTION OR DESIGN. FAIRCHILD DOES NOT ASSUME ANY LIABILITY ARISING OUT OF THE APPLICATION OR USE OF ANY PRODUCT OR CIRCUIT DESCRIBED HEREIN; NEITHER DOES IT CONVEY ANY LICENSE UNDER ITS PATENT RIGHTS, NOR THE RIGHTS OF OTHERS.

LIFE SUPPORT POLICY

FAIRCHILD'S PRODUCTS ARE NOT AUTHORIZED FOR USE AS CRITICAL COMPONENTS IN LIFE SUPPORT DEVICES OR SYSTEMS WITHOUT THE EXPRESS WRITTEN APPROVAL OF THE PRESIDENT OF FAIRCHILD SEMICONDUCTOR CORPORATION. As used herein:

1. Life support devices or systems are devices or systems which, (a) are intended for surgical implant into the body, or (b) support or sustain life, and (c) whose failure to perform when properly used in accordance with instructions for use provided in the labeling, can be reasonably expected to result in a significant injury of the user.
2. A critical component in any component of a life support device or system whose failure to perform can be reasonably expected to cause the failure of the life support device or system, or to affect its safety or effectiveness.