



FUKUCOM COMPANY LTD.

福 靈 有 限 公 司

FLAT P, 3/F, EVEREST INDUSTRIAL CENTRE, 396 KWUN TONG ROAD,
KWUN TONG, KOWLOON, HONG KONG.
TEL: 2790-0314 FAX: 2790-0206

SS9018

FAIRCHILD
SEMICONDUCTOR®

SS9018

AM/FM Amplifier, Local Oscillator of FM/VHF Tuner

- High Current Gain Bandwidth Product $f_T=1.1$ GHz (Typ)

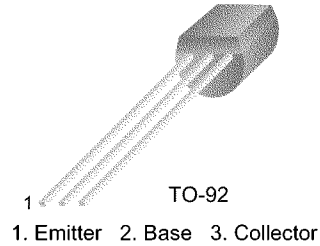

NPN Epitaxial Silicon Transistor

Absolute Maximum Ratings $T_a=25^\circ\text{C}$ unless otherwise noted

| Symbol | Parameter | Ratings | Units |
|-----------|-----------------------------|-----------|------------------|
| V_{CBO} | Collector-Base Voltage | 30 | V |
| V_{CEO} | Collector-Emitter Voltage | 15 | V |
| V_{EBO} | Emitter-Base Voltage | 5 | V |
| I_C | Collector Current | 50 | mA |
| P_C | Collector Power Dissipation | 400 | mW |
| T_J | Junction Temperature | 150 | $^\circ\text{C}$ |
| T_{STG} | Storage Temperature | -55 ~ 150 | $^\circ\text{C}$ |

Electrical Characteristics $T_a=25^\circ\text{C}$ unless otherwise noted

| Symbol | Parameter | Test Condition | Min. | Typ. | Max. | Units |
|---------------|--------------------------------------|---|------|------|------|-------|
| BV_{CBO} | Collector-Base Breakdown Voltage | $I_C=100\mu\text{A}, I_E=0$ | 30 | | | V |
| BV_{CEO} | Collector-Emitter Breakdown Voltage | $I_C=1.0\text{mA}, I_B=0$ | 15 | | | V |
| BV_{EBO} | Emitter-Base Breakdown Voltage | $I_E=100\mu\text{A}, I_C=0$ | 5 | | | V |
| I_{CBO} | Collector Cut-off Current | $V_{CB}=12\text{V}, I_E=0$ | | | 50 | nA |
| h_{FE} | Emitter Cut-off Current | $V_{CE}=5\text{V}, I_C=1.0\text{mA}$ | 28 | 100 | 198 | |
| $V_{CE(sat)}$ | Collector-Emitter Saturation Voltage | $I_C=10\text{mA}, I_B=1\text{mA}$ | | | 0.5 | V |
| C_{ob} | Output Capacitance | $V_{CB}=10\text{V}, I_E=0$ $f=1\text{MHz}$ | | 1.3 | 1.7 | pF |
| f_T | Current Gain Bandwidth Product | $V_{CE}=5\text{V}, I_C=5\text{mA}$ | 700 | 1100 | | MHz |

h_{FE} Classification

| Classification | D | E | F | G | H | I |
|----------------|---------|---------|---------|----------|----------|-----------|
| h_{FE} | 28 ~ 45 | 39 ~ 60 | 54 ~ 80 | 72 ~ 108 | 97 ~ 146 | 132 ~ 198 |



FUKUCOM COMPANY LTD.

福 靈 有 限 公 司

FLAT P, 3/F, EVEREST INDUSTRIAL CENTRE, 396 KWUN TONG ROAD,
KWUN TONG, KOWLOON, HONG KONG.

TEL: 2790-0314 FAX: 2790-0206

SS9018

Typical Characteristics

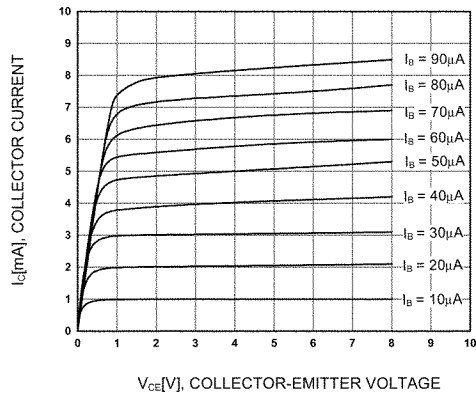

Figure 1. Static Characteristic

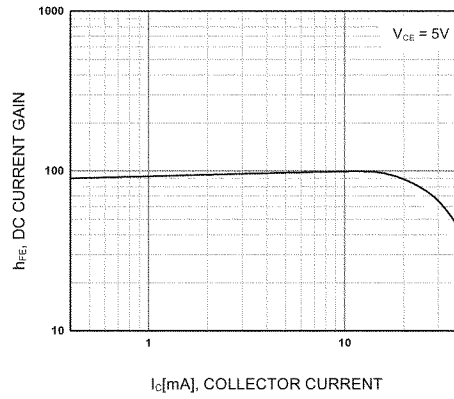

Figure 2. DC current Gain

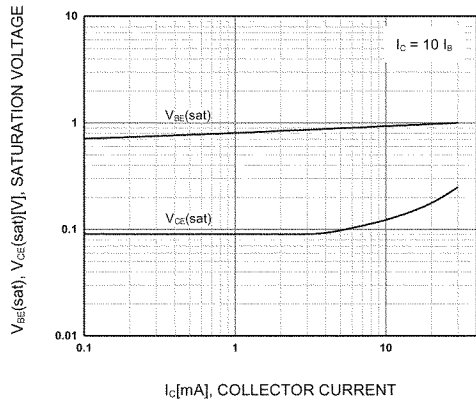

Figure 3. Base-Emitter Saturation Voltage
Collector-Emitter Saturation Voltage

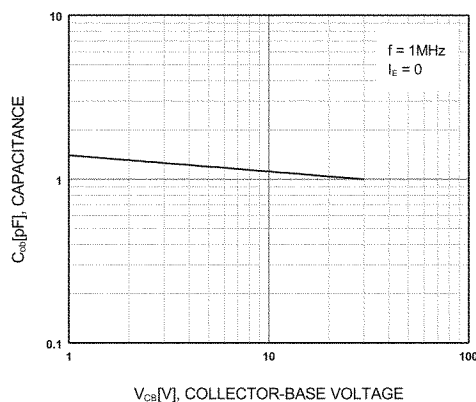

Figure 4. Output Capacitance

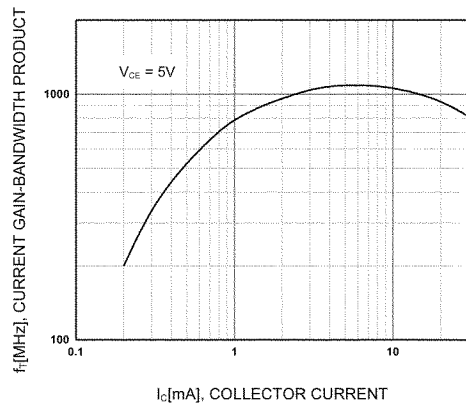

Figure 5. Current Gain Bandwidth Product



FUKUCOM COMPANY LTD.

福 靈 有 限 公 司

FLAT P, 3/F, EVEREST INDUSTRIAL CENTRE, 396 KWUN TONG ROAD,
KWUN TONG, KOWLOON, HONG KONG.

TEL: 2790-0314 FAX: 2790-0206

Package Demensions

SS9018

TO-92

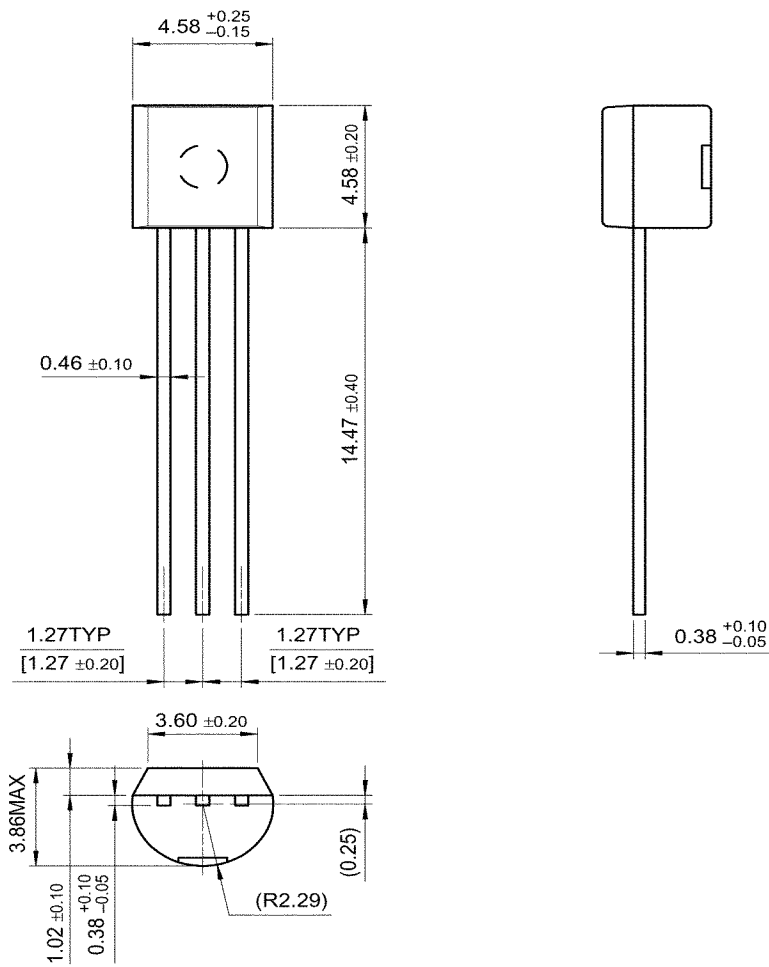

Dimensions in Millimeters