



FUKUCOM COMPANY LTD.

福 靈 有 限 公 司

FLAT P, 3/F., EVEREST INDUSTRIAL CENTRE, 396 KWUN TONG ROAD,
KWUN TONG, KOWLOON, HONG KONG.

TEL: 852-2790 0314 FAX: 852-2790 0206



AUTOMOTIVE RECTIFIER

RA501 thru RA504

VOLTAGE RANGE
CURRENT

100 to 400 Volts
50 Amperes

FEATURES

- Low cost
- High surge capability
- Diffused Junction
- Low Leakage Current
- High Temperature soldering guaranteed:
260 °C / 10 second, 0.16" (4.06mm) from case

MECHANICAL DATA

- Case: Transfer molded plastic
- Polarity: As marked
- Lead: Plated axial lead, solderable per MIL – STD-202E Method 208C
- Mounting torque: 5 in.-lbs.max.
- Weight: 0.08 ounces, 2.24 grams

MAXIMUM RATINGS AND ELECTRICAL CHARACTERISTICS

- Ratings at 25 °C ambient temperature unless otherwise specified
- Single Phase, half wave, 60Hz, resistive or inductive load
- For capacitive load derate current by 20%

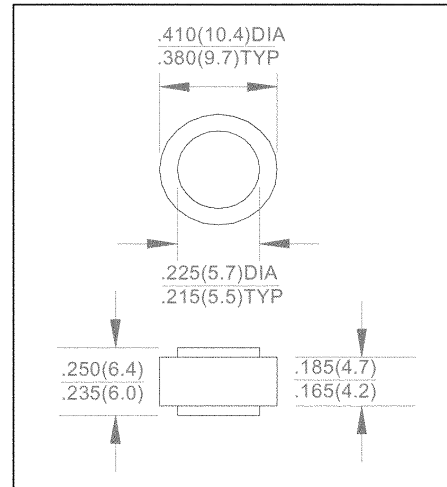

	SYMBOLS	RA501	RA502	RA503	RA504	UNIT
Maximum Repetitive Peak Reverse Voltage	V_{RRM}	100	200	300	400	Volts
Maximum RMS Voltage	V_{RMS}	70	140	210	280	Volts
Maximum DC Blocking Voltage	V_{DC}	100	200	300	400	Volts
Maximum Average Forward Rectified Current, At $T_c = 55^\circ\text{C}$	$I_{(AV)}$	50				Amps
Peak Forward Surge Current 8.3ms single half sine wave superimposed on Rated load (JEDEC method)	I_{FSM}	600				Amps
Maximum Instantaneous Forward Voltage @ 80A	V_F	1.06				Volts
Maximum DC Reverse Current at Rated DC Blocking Voltage per element	I_R	2.0 500				μA
Maximum Reverse Recovery Time	t_{rr}	3.0				nS
Typical Junction Capacitance (Note 1)	C_J	300				pF
Typical Thermal Resistance (Note 2)	$R_{\theta JC}$	0.8				$^\circ\text{C/W}$
Operating Junction Temperature Range	T_J	-50 to +175				$^\circ\text{C}$
Storage Temperature Range	T_{STG}	-50 to +175				$^\circ\text{C}$
Polarity and voltage demotion color band		Yellow	Silver	Orange	Green	

Notes:

1. Measured at 1MHz and applied reverse of 4.0 volts DC.
2. Thermal Resistance Junction to case.



FUKUCOM COMPANY LTD.

福 靈 有 限 公 司

FLAT P, 3/F., EVEREST INDUSTRIAL CENTRE, 396 KWUN TONG ROAD,
KWUN TONG, KOWLOON, HONG KONG.

TEL: 852-2790 0314 FAX: 852-2790 0206



BUTTON AUTOMOTIVE RECTIFIER

RA501 THRU RA504

VOLTAGE RANGE 100 to 400 Volts
CURRENT 50.0 Amperes

RATINGS AND CHARACTERISTIC CURVES RA501 THRU RA504

FIG.1-TYPICAL FORWARD CURRENT DERATING CURVE

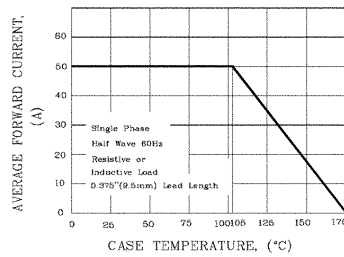

FIG.2-MAXIMUM NON-REPETITIVE PEAK FORWARD SURGE CURRENT

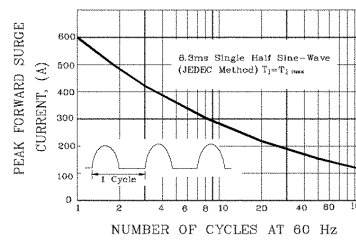

FIG.3-TYPICAL INSTANTANEOUS FORWARD CHARACTERISTICS

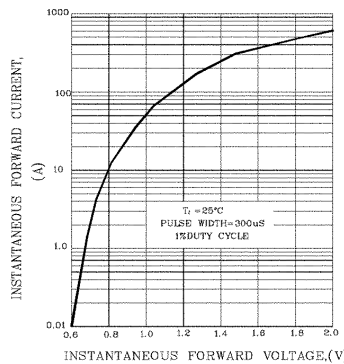

FIG.4-TYPICAL JUNCTION CAPACITANCE

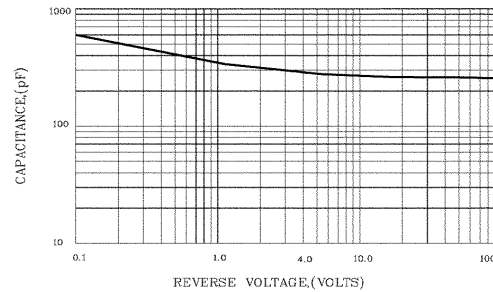

FIG.5-TYPICAL REVERSE CHARACTERISTICS

