



FUKUCOM COMPANY LTD.

福 靈 有 限 公 司

FLAT P, 3/F., EVEREST INDUSTRIAL CENTRE, 396 KWUN TONG ROAD,
KWUN TONG, KOWLOON, HONG KONG.

TEL: 852-2790 0314 FAX: 852-2790 0206

	RECTIFIER SPECIALISTS	SK32 THRU SK38
---	------------------------------	-------------------------------

TECHNICAL SPECIFICATIONS OF SURFACE MOUNT SCHOTTKY BARRIER RECTIFIER

VOLTAGE RANGE - 20 to 80 Volts

CURRENT - 3.0 Amperes

FEATURES

- * Ideal for surface mounted applications
- * Low leakage current
- * Glass passivated junction

MECHANICAL DATA

- * Case: Molded plastic
- * Epoxy: UL 94V-0 rate flame retardant
- * Terminals: Solder plated solderable per MIL-STD-750, Method 2026
- * Polarity: As marked
- * Mounting position: Any
- * Weight: 0.24 gram



SMC (DO-214AB)

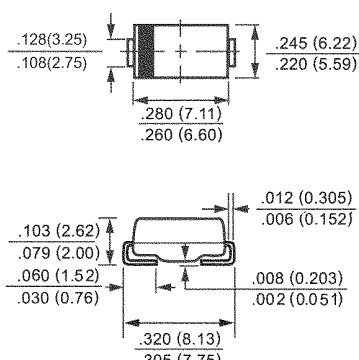

Dimensions in inches and (millimeters)

MAXIMUM RATINGS AND ELECTRICAL CHARACTERISTICS

Ratings at 25 °C ambient temperature unless otherwise specified.
Single phase, half wave, 60 Hz, resistive or inductive load.
For capacitive load, derate current by 20%.

	SYMBOL	SK32	SK33	SK34	SK35	SK36	SK38	UNITS
Maximum Recurrent Peak Reverse Voltage	VRRM	20	30	40	50	60	80	Volts
Maximum RMS Voltage	VRMS	14	21	28	35	42	56	Volts
Maximum DC Blocking Voltage	VDC	20	30	40	50	60	80	Volts
Maximum Average Forward Rectified Current at Derating Lead Temperature	IO	3.0						Amps
Peak Forward Surge Current 8.3 ms single half sine-wave superimposed on rated load (JEDEC Method)	IFSM	100						Amps
Maximum Instantaneous Forward Voltage at 3.0A DC	VF	0.55		0.70		0.85		Volts
Maximum DC Reverse Current at Rated DC Blocking Voltage	IR	2.0						mAmps
		20						
Typical Thermal Resistance (Note 1)	RθJA	55						°C/W
Typical Junction Capacitance (Note 2)	CJ	200						pF
Operating Temperature Range	TJ	-55 to + 125						°C
Storage Temperature Range	TSTG	-55 to + 150						°C

NOTES : 1. Thermal Resistance (Junction to Ambient).
2. Measured at 1 MHz and applied reverse voltage of 4.0 volts.
3. P.C.B Mounted with 0.4X0.4in²(10.0X10.0mm²) copper pad area.



FUKUCOM COMPANY LTD.

福 靈 有 限 公 司

FLAT P, 3/F., EVEREST INDUSTRIAL CENTRE, 396 KWUN TONG ROAD,
KWUN TONG, KOWLOON, HONG KONG.

TEL: 852-2790 0314 FAX: 852-2790 0206

RATING AND CHARACTERISTIC CURVES (SK32 THRU SK38)

FIG. 1 - TYPICAL FORWARD CURRENT DERATING CURVE

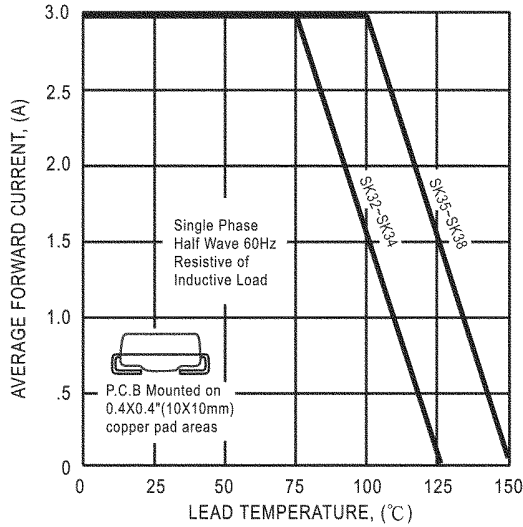

FIG. 2 - TYPICAL REVERSE CHARACTERISTICS

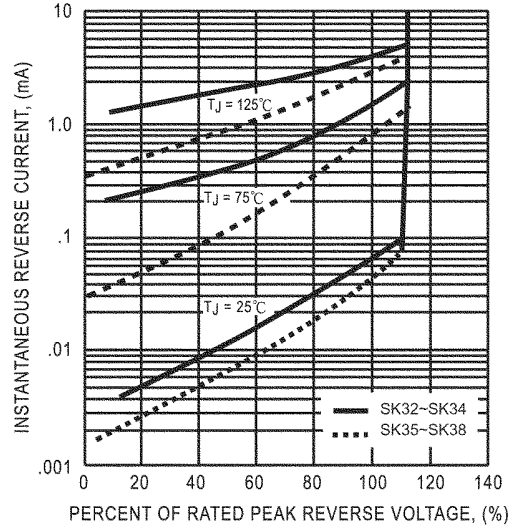

FIG. 3 - TYPICAL INSTANTANEOUS FORWARD CHARACTERISTICS

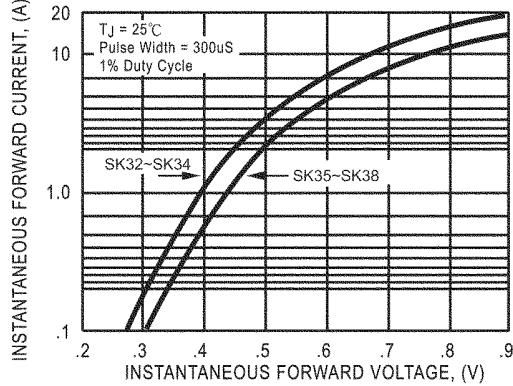

FIG. 4 - TYPICAL JUNCTION CAPACITANCE

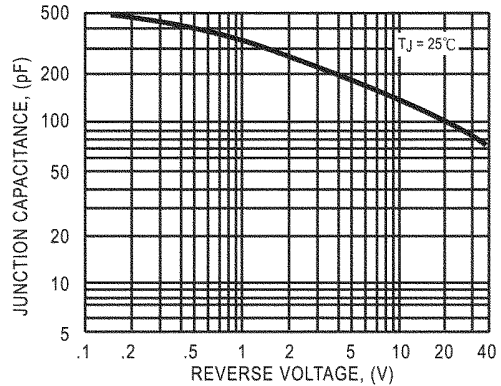

FIG. 5 - MAXIMUM NON-REPETITIVE FORWARD SURGE CURRENT

