



FUKUCOM COMPANY LTD.

福 靈 有 限 公 司

FLAT P, 3/F, EVEREST INDUSTRIAL CENTRE, 396 KWUN TONG ROAD,  
KWUN TONG, KOWLOON, HONG KONG.

TEL: 2790-0314 FAX: 2790-0206

	<p>RECTIFIER SPECIALISTS</p>	<p>S1A THRU S1M</p>
---	------------------------------	-----------------------------

TECHNICAL SPECIFICATIONS OF SURFACE MOUNT SILICON RECTIFIER

VOLTAGE RANGE - 50 to 1000 Volts

CURRENT - 1.0 Ampere

**FEATURES**

- \* Ideal for surface mounted applications
- \* Low leakage current
- \* Glass passivated junction

**MECHANICAL DATA**

- \* Case: Molded plastic
- \* Epoxy: UL 94V-0 rate flame retardant
- \* Terminals: Solder plated, solderable per MIL-STD-750, Method 2026
- \* Polarity: As marked
- \* Mounting position: Any
- \* Weight: 0.093 gram

  
 SMB (DO-214AA)

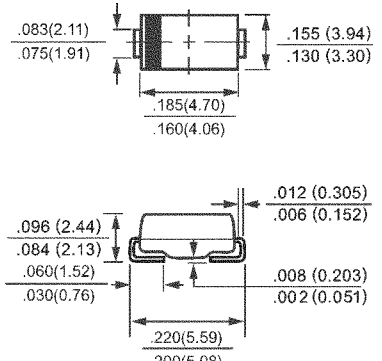

Dimensions in inches and (millimeters)

**MAXIMUM RATINGS AND ELECTRICAL CHARACTERISTICS**

Ratings at 25 °C ambient temperature unless otherwise specified.  
Single phase, half wave, 60 Hz, resistive or inductive load.  
For capacitive load, derate current by 20%.

	SYMBOL	S1A	S1B	S1D	S1G	S1J	S1K	S1M	UNITS
Maximum Recurrent Peak Reverse Voltage	VRRM	50	100	200	400	600	800	1000	Volts
Maximum RMS Voltage	VRMS	35	70	140	280	420	560	700	Volts
Maximum DC Blocking Voltage	VDC	50	100	200	400	600	800	1000	Volts
Maximum Average Forward Rectified Current at TA = 75 °C	IO	1.0							Amps
Peak Forward Surge Current 8.3 ms single half sine-wave superimposed on rated load (JEDEC Method)	IFSM	30							Amps
Maximum Instantaneous Forward Voltage at 1.0A DC	VF	1.1							Volts
Maximum DC Reverse Current at Rated DC Blocking Voltage	IR	@TA = 25 °C							uAmps
		@TA = 100 °C							
Maximum Reverse Recovery Time (Note 3)	trr	2.5							uSec
Typical Thermal Resistance (Note 2)	RθJL	12							°C/W
Typical Junction Capacitance (Note 1)	Cj	30							pF
Operating and Storage Temperature Range	TJ, TSTG	-65 to + 175							°C

NOTES : 1. Measured at 1 MHz and applied reverse voltage of 4.0 volts.  
2. Thermal Resistance (Junction to Ambient), 0.2x0.2in<sup>2</sup> (5X5mm<sup>2</sup>) copper pads to each terminal.  
3. Test Conditions: IF=0.5A, IR=1.0A, IRR=0.25A.



FUKUCOM COMPANY LTD.

福 靈 有 限 公 司

FLAT P, 3/F, EVEREST INDUSTRIAL CENTRE, 396 KWUN TONG ROAD,  
KWUN TONG, KOWLOON, HONG KONG.  
TEL: 2790-0314 FAX: 2790-0206

RATING AND CHARACTERISTIC CURVES (S1A THRU S1M)

FIG. 1 - TYPICAL FORWARD CURRENT DERATING CURVE

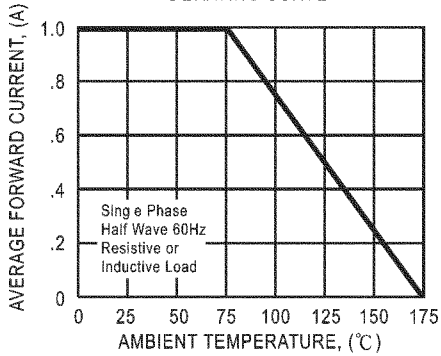

FIG. 2 - MAXIMUM NON-REPETITIVE FORWARD SURGE CURRENT

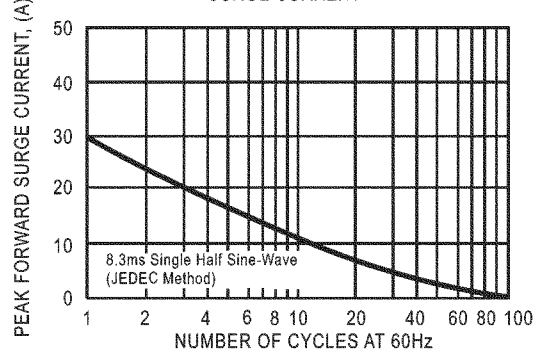

FIG. 3 - TYPICAL INSTANTANEOUS FORWARD CHARACTERISTICS

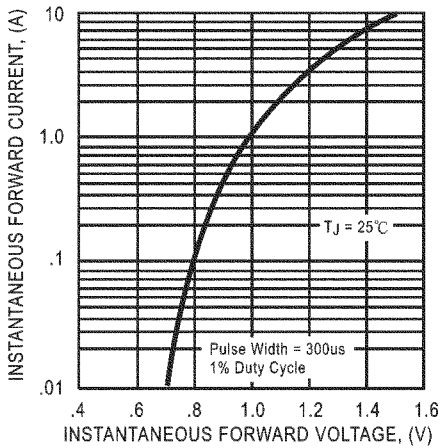

FIG. 4 - TYPICAL REVERSE CHARACTERISTICS

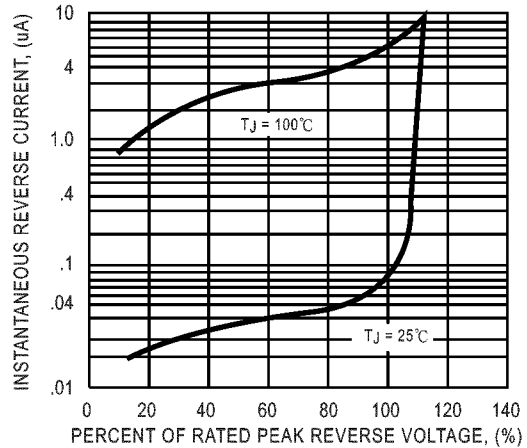

FIG. 5 - TYPICAL JUNCTION CAPACITANCE

