



FUKUCOM COMPANY LTD.

福 靈 有 限 公 司

FLAT P, 3/F, EVEREST INDUSTRIAL CENTRE, 396 KWUN TONG ROAD,
KWUN TONG, KOWLOON, HONG KONG.

TEL: 2790-0314 FAX: 2790-0206

	<p>RECTIFIER SPECIALISTS</p>	<p>HER151 THRU HER158</p>
---	------------------------------	-----------------------------------

TECHNICAL SPECIFICATIONS OF HIGH EFFICIENCY RECTIFIER
VOLTAGE RANGE - 50 to 1000 Volts CURRENT - 1.5 Amperes

FEATURES

- * Low power loss, high efficiency
- * Low leakage
- * Low forward voltage drop
- * High current capability
- * High speed switching
- * High surge capability
- * High reliability

MECHANICAL DATA

- * Case: Molded plastic
- * Epoxy: UL 94V-0 rate flame retardant
- * Lead: MIL-STD-202E, Method 208 guaranteed
- * Polarity: Color band denotes cathode end
- * Mounting position: Any
- * Weight: 0.4 gram

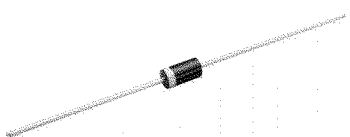

DO-15

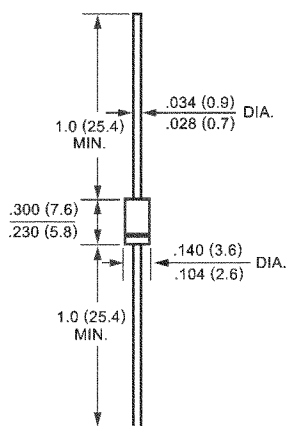

Dimensions in inches and (millimeters)

MAXIMUM RATINGS AND ELECTRICAL CHARACTERISTICS

Ratings at 25 °C ambient temperature unless otherwise specified.
Single phase, half wave, 60 Hz, resistive or inductive load.
For capacitive load, derate current by 20%.

	SYMBOL	HER151	HER152	HER153	HER154	HER155	HER156	HER157	HER158	UNITS
Maximum Recurrent Peak Reverse Voltage	V _{RRM}	50	100	200	300	400	600	800	1000	Volts
Maximum RMS Voltage	V _{RMS}	35	70	140	210	280	420	560	700	Volts
Maximum DC Blocking Voltage	V _{DC}	50	100	200	300	400	600	800	1000	Volts
Maximum Average Forward Rectified Current at T _A = 50°C	I _O	1.5								Amps
Peak Forward Surge Current 8.3 ms single half sine-wave superimposed on rated load (JEDEC Method)	I _{FSM}	60								Amps
Maximum Instantaneous Forward Voltage at 1.5A DC	V _F	1.0		1.3		1.7				Volts
Maximum DC Reverse Current at Rated DC Blocking Voltage T _A = 25°C	I _R	5.0								uAmps
Maximum Full Load Reverse Current Average, Full Cycle .375*(9.5mm) lead length at T _L = 55°C		100								uAmps
Maximum Reverse Recovery Time (Note 1)	t _{rr}	50				75				nSec
Typical Junction Capacitance (Note 2)	C _J	30				20				pF
Operating and Storage Temperature Range	T _J , T _{STG}	-65 to + 150								°C

NOTES : 1. Test Conditions: I_F = 0.5A, I_R = 1.0A, I_{RR} = 0.25A
2. Measured at 1 MHz and applied reverse voltage of 4.0 volts



FUKUCOM COMPANY LTD.

福靈有限公司

FLAT P, 3/F., EVEREST INDUSTRIAL CENTRE, 396 KWUN TONG ROAD,
KWUN TONG, KOWLOON, HONG KONG.

TEL: 2790-0314 FAX: 2790-0206

RATING AND CHARACTERISTIC CURVES (HER151 THRU HER158)

FIG. 1 - TEST CIRCUIT DIAGRAM AND REVERSE RECOVERY TIME CHARACTERISTIC

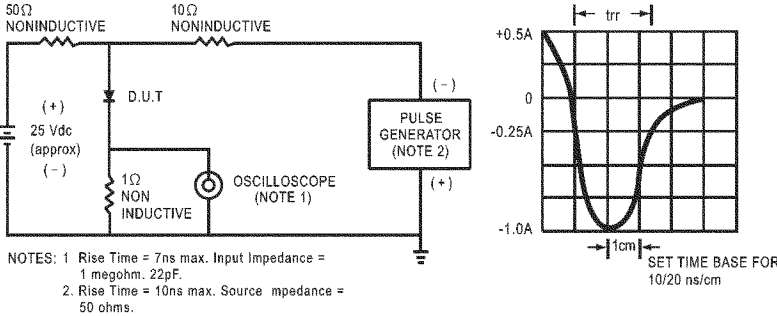

FIG. 2 - TYPICAL FORWARD CURRENT DERATING CURVE

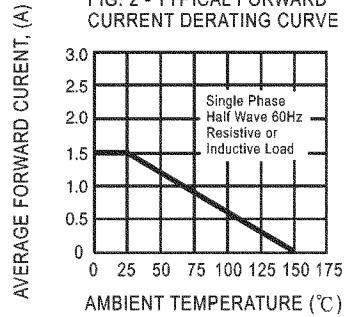

FIG. 3 - TYPICAL REVERSE CHARACTERISTICS

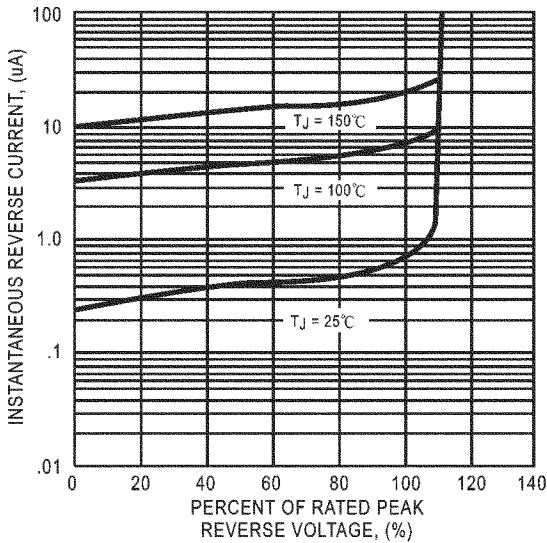

FIG. 4 - TYPICAL INSTANTANEOUS FORWARD CHARACTERISTICS

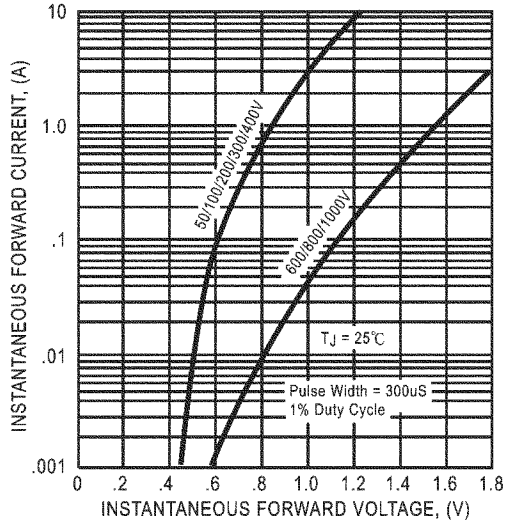

FIG. 5 - MAXIMUM NON-REPETITIVE FORWARD SURGE CURRENT

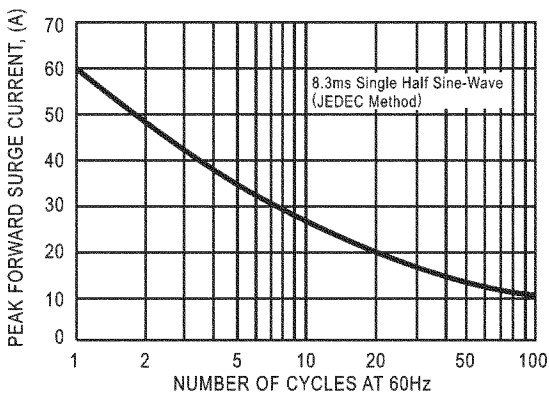

FIG. 6 - TYPICAL JUNCTION CAPACITANCE

