



FUKUCOM COMPANY LTD.  
RECTIFIER SPECIALISTS

1N4001  
THRU  
1N4007

TECHNICAL SPECIFICATIONS OF SILICON RECTIFIER  
VOLTAGE RANGE - 50 to 1000 Volts    CURRENT - 1.0 Ampere

FEATURES

- \* Low cost
- \* Low leakage
- \* Low forward voltage drop
- \* High current capability

MECHANICAL DATA

- \* Case: Molded plastic
- \* Epoxy: UL 94V-0 rate flame retardant
- \* Lead: MIL-STD-202E, Method 208 guaranteed
- \* Polarity: Color band denotes cathode end
- \* Mounting position: Any
- \* Weight: 0.33 gram

MAXIMUM RATINGS AND ELECTRICAL CHARACTERISTICS

Ratings at 25°C ambient temperature unless otherwise specified.  
Single phase, half wave, 60 Hz, resistive or inductive load.  
For capacitive load, derate current by 20%.

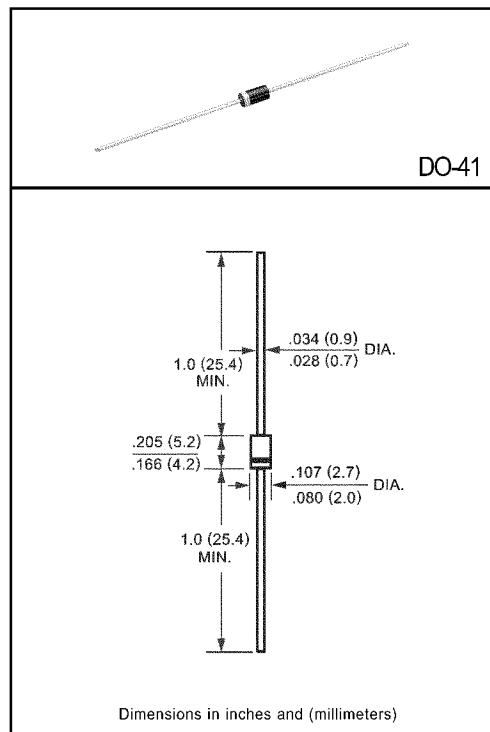

	SYMBOL	1N4001	1N4002	1N4003	1N4004	1N4005	1N4006	1N4007	UNITS
Maximum Recurrent Peak Reverse Voltage	V <sub>RRM</sub>	50	100	200	400	600	800	1000	Volts
Maximum RMS Voltage	V <sub>RMS</sub>	35	70	140	280	420	560	700	Volts
Maximum DC Blocking Voltage	V <sub>DC</sub>	50	100	200	400	600	800	1000	Volts
Maximum Average Forward Rectified Current at T <sub>A</sub> = 75°C	I <sub>O</sub>	1.0							Amps
Peak Forward Surge Current 8.3 ms single half sine-wave superimposed on rated load (JEDEC Method)	I <sub>FSM</sub>	30							Amps
Maximum Instantaneous Forward Voltage at 1.0A DC	V <sub>F</sub>	1.1							Volts
Maximum DC Reverse Current at Rated DC Blocking Voltage	@T <sub>A</sub> = 25°C	5.0							uAmps
	@T <sub>A</sub> = 100°C	500							
Maximum Full Load Reverse Current Average, Full Cycle .375"(9.5mm) lead length at T <sub>L</sub> = 75°C	I <sub>R</sub>	30							uAmps
Typical Junction Capacitance (Note)	C <sub>J</sub>	15							pF
Typical Thermal Resistance	R <sub>θJA</sub>	50							°C/W
Operating and Storage Temperature Range	T <sub>J</sub> , T <sub>STG</sub>	-65 to + 175							°C

NOTES : Measured at 1 MHz and applied reverse voltage of 4.0 volts

RATING AND CHARACTERISTIC CURVES (1N4001 THRU 1N4007)

FIG. 1 - TYPICAL FORWARD CURRENT DERATING CURVE

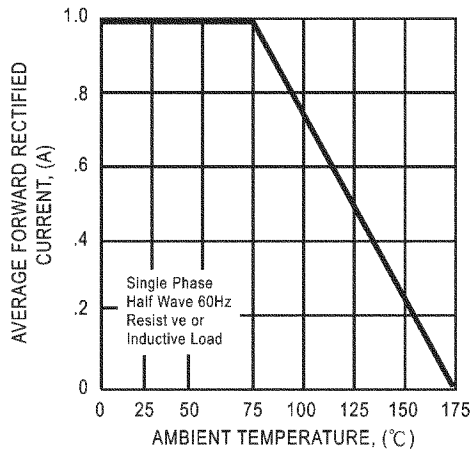

FIG. 2 - TYPICAL INSTANTANEOUS FORWARD CHARACTERISTICS

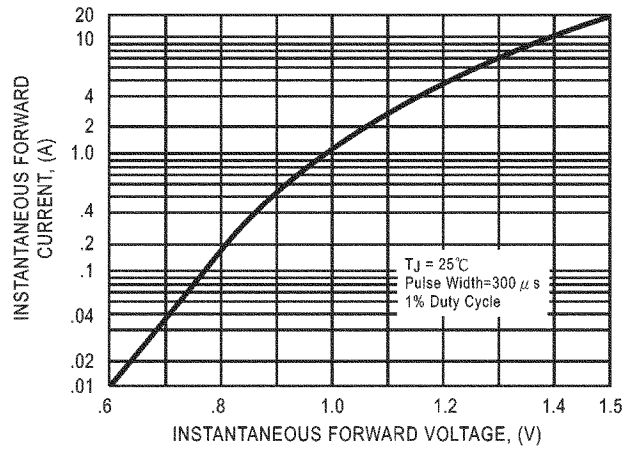

FIG. 3 - MAXIMUM NON-REPETITIVE FORWARD SURGE CURRENT

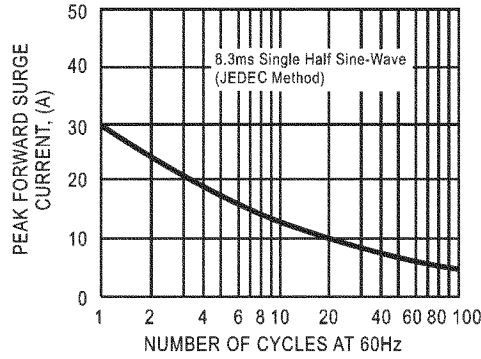

FIG. 4 - TYPICAL REVERSE CHARACTERISTICS

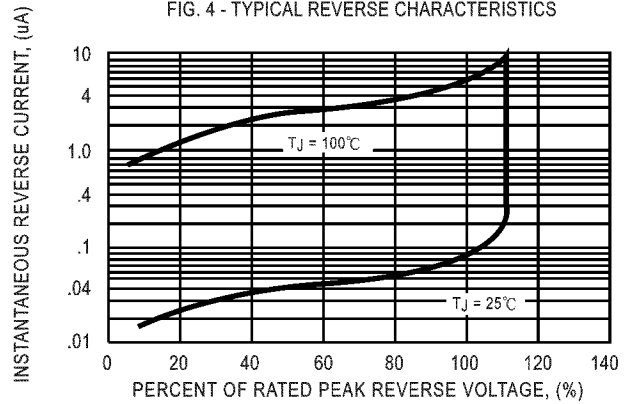

FIG. 5 - TYPICAL JUNCTION CAPACITANCE

